

2/90[®]
Sign Systems



Helping people find their way™

Helping people find their way™

All 2/90 Sign Systems products are designed with people in mind. People looking to create clarity. People looking for a meeting place or a library book. People looking to project clean design and professionalism. And, people looking for turnkey wayfinding solutions that are easy to maintain and meet government regulations.

Wherever wayfinding products are needed, 2/90 Sign Systems is ready to help design-professionals, facility owners and more with our unparalleled products, knowledge and service. Whether you're updating an outdated wayfinding system, upgrading to meet current regulations, or you're implementing a system in a new, refurbished, or expanding facility, 2/90 Sign Systems is **helping people find their way.**



- For over 40 years 2/90 Sign Systems wayfinding solutions have been directing people through corporate, healthcare, education, hospitality and government spaces.
- Turnkey wayfinding solutions from concept and design, to installation, maintenance and repair.
- Regulation compliant for your protection as a design-professional or facility owner.
- Easily updated modular sign systems that meet the needs of changing environments.
- A near-infinite variety of size, finish and configuration options to meet your specific design goals.
- Interior, exterior – static and digital signage solutions.
- Made in the U.S.A. for the industry's quickest turnaround times.

Visit 290signs.com to learn more about how 2/90 Sign Systems is helping people find their way.

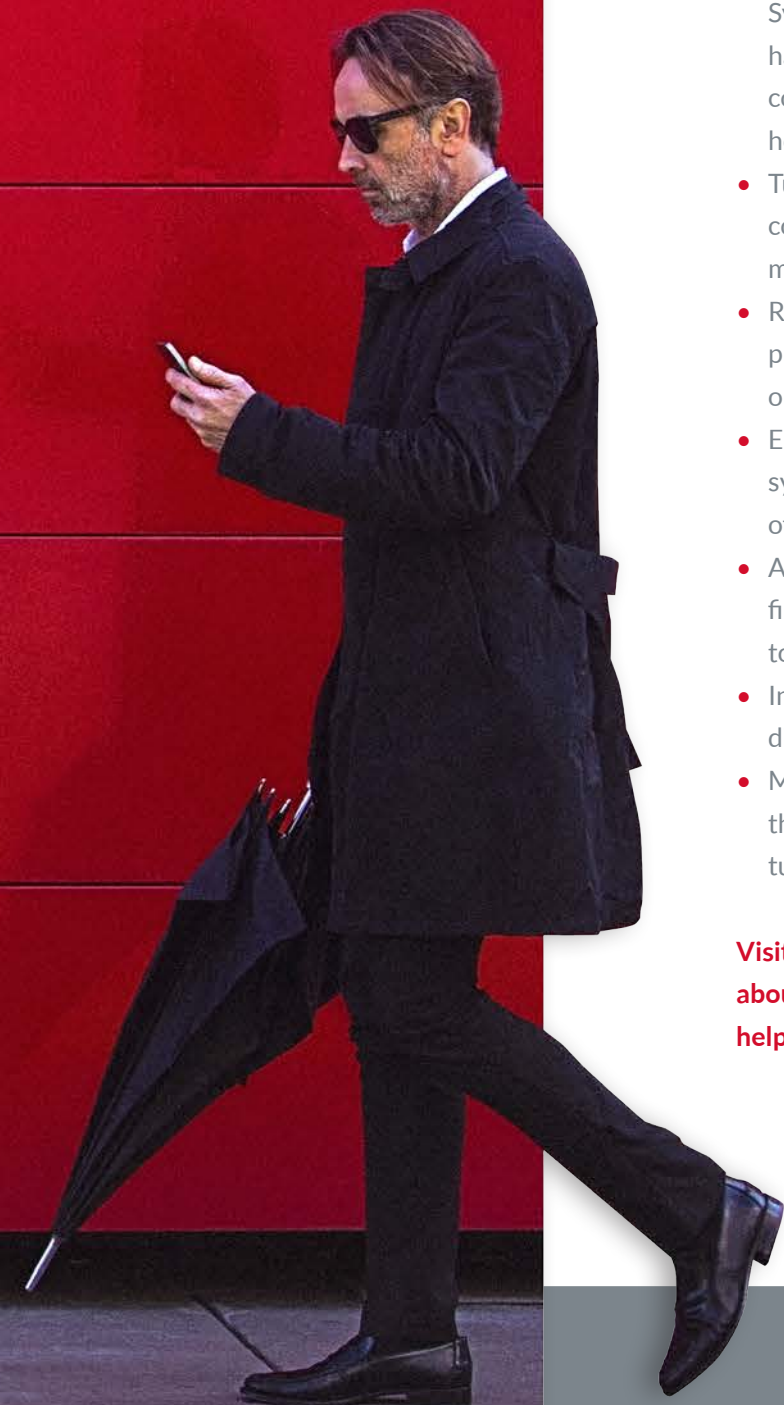



Sometimes the smallest step in the right direction ends up being the biggest step.

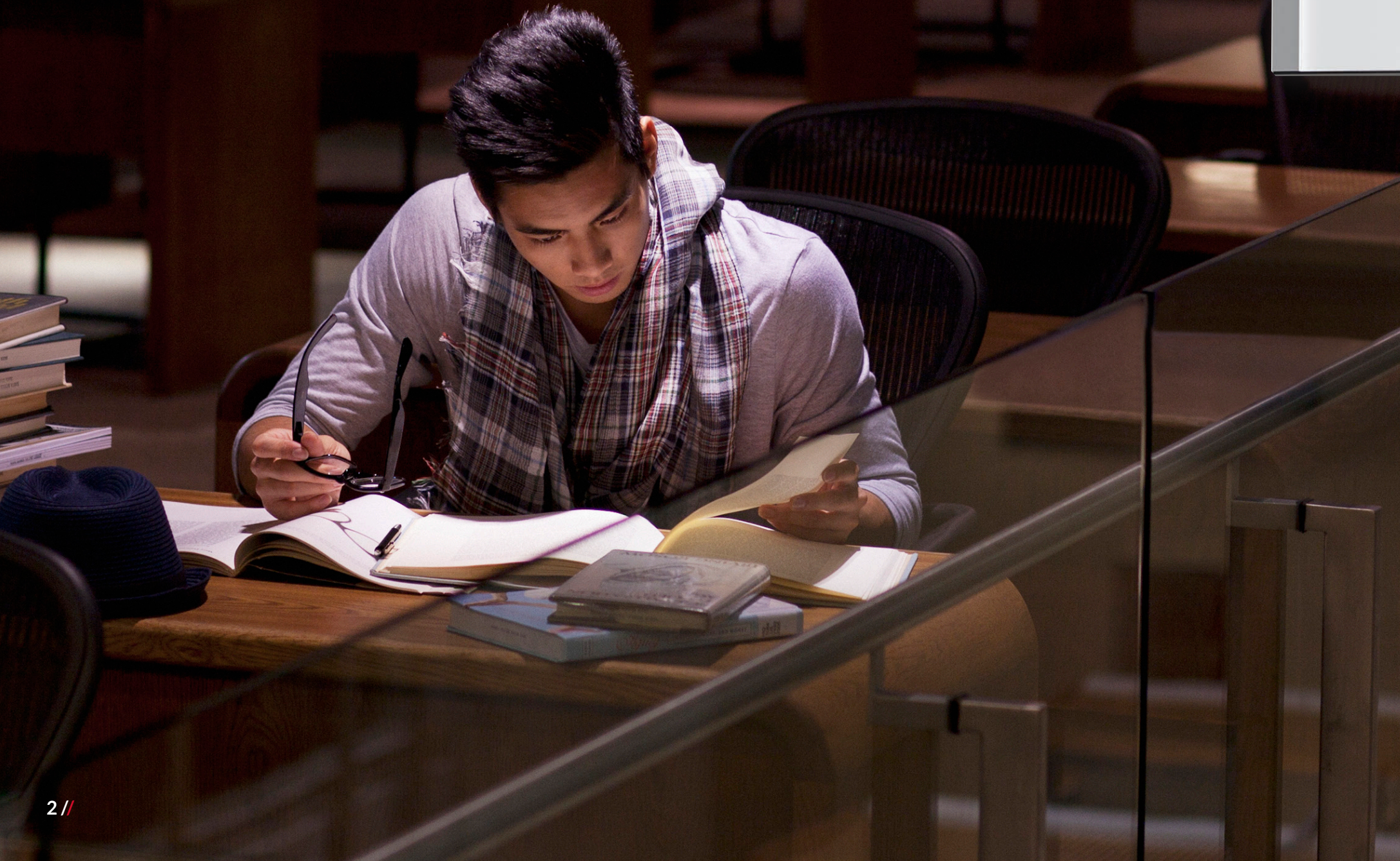

4-335

4-335

Lindsay Jones

Starting college life... the new people, the courses, the multiple buildings, classrooms and more can be daunting. A turnkey wayfinding solution from 2/90 Sign Systems makes it easy to navigate a new environment, making college life just a little bit easier. Wherever wayfinding products are needed, there is a 2/90 Sign Systems solution that is **helping people find their way.**

2/90[®]
Sign Systems

Helping people find their way™



Arc[®]

modular sign system



The Arc modular sign system is a simple yet powerful solution for facilities such as schools, universities, and libraries that require frequent changes. Like all 2/90 Sign Systems products, Arc inserts can be fabricated from almost any one of our numerous insert materials and copy options. To create a seamless look and end-user flexibility, Arc is designed to accommodate standard paper sizes. With Arc, changing names, titles, departments and messages is easy. Choose Arc when you're looking to create a clean, three-dimensional look with a curved profile.



Accent strips separate multiple inserts and add additional detail.

Signs for every need; identification, regulation, information and direction.



Our modular sign systems include a collection of wall, cubicle, ceiling and freestanding mounts, including this Arc table top mount sign.

SmartStrip[™]

Hold a variety of messages by adding our SmartStrip to any of our modular sign systems. When purchased separately, they can be installed next to a sign or used alone to hold messages or postings.



Arc modular sign with SmartStrip accessory in satin natural aluminum finish with black caps.

DATE	TIME
While You Were Out	
M. _____	
OF _____	<input type="checkbox"/> TELEPHONED
PHONE _____	<input type="checkbox"/> CAME TO SEE YOU
CELL _____	<input type="checkbox"/> RETURNED YOUR CALL
FAX _____	<input type="checkbox"/> PLEASE CALL
Message	<input type="checkbox"/> WILL CALL AGAIN
_____	<input type="checkbox"/> WANTS TO SEE YOU

4-8111 1-3002	SIGNED



Helping people find their way[™]



Arc[®]

modular sign system

The Arc modular sign system can be paired with accessories such as our SmartInsert™, SmartStrip™ or pen holder, to create an effect as unique as your company or space. **Sturdy and tamper-resistant, Arc is compliant with ADA regulations when used with ADA-compliant graphics/copy options.**

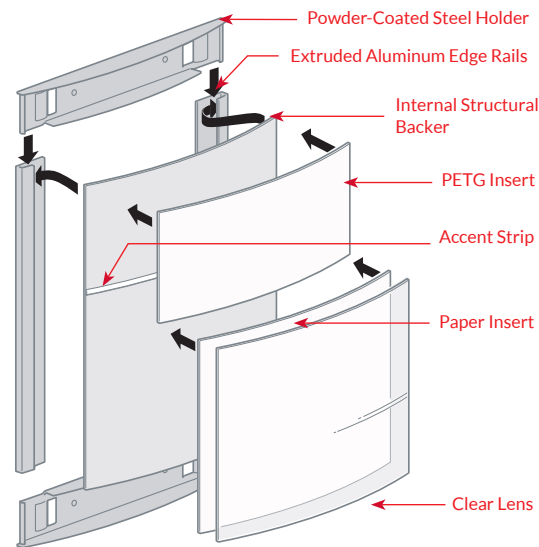

As your facility grows, our modular sign systems can accommodate change. Combine Arc signs with a design element for a seamless update.



Remove the clear, non-glare lens using the provided suction tool. Then simply insert the paper and replace the protective, tamper-resistant lens.



Easily update information with your own printed paper inserts.

Like all of our modular sign systems, Arc modular signs accept any document, photograph or graphic image printed on standard paper sizes. Die-cut perforated paper is available from 2/90 Sign Systems in a variety of sizes, colors and textures for easy in-house maintenance.



Arc signs are available with either a horizontal or vertical curve.



Horizontal Arc



Vertical Arc



Walk with me... we'll figure out where we're going together.

4-335



Lindsay Jones

Hospital visitors and patients often have a lot on their minds. Navigating through a facility should not be one of them. 2/90 Sign Systems provides turnkey wayfinding solutions that are designed with people in mind. Wherever wayfinding products are needed, there is a 2/90 Sign Systems solution that is **helping people find their way.**



Helping people find their way™



Slide™

modular sign system



Almost 40 years ago, we created Slide modular signs – a revolutionary wayfinding solution. With its open-ended functionality, Slide system users can create, or update their look from an infinite combinations of three basic components. A personalized Slide wayfinding system sends the right message about you and your facility, engaging visitors and directing them to their intended location. **Choose Slide when you're looking for eye-catching detail elements such as end caps, various thicknesses and more.**

A VitalSign medical alert system allows you to communicate valuable information to patients, visitors and staff.

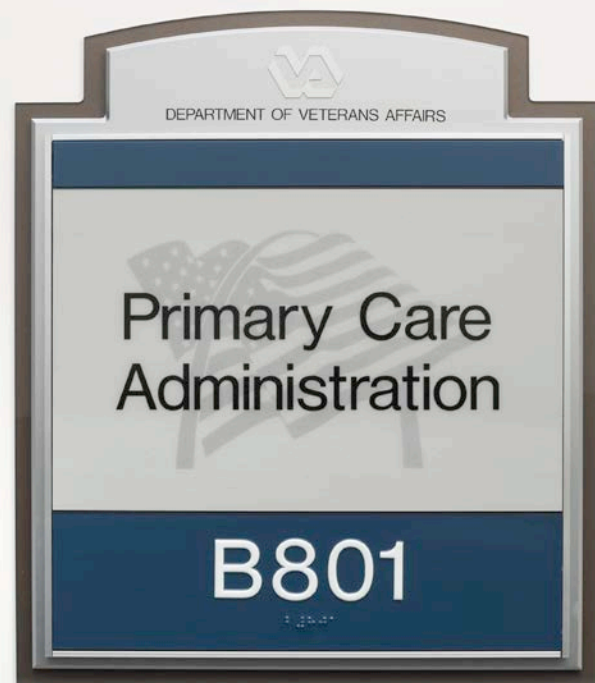

Add detail and additional functionality by designing an enhanced backer that showcases your brand.

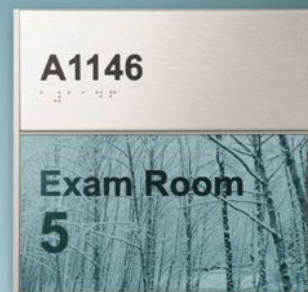
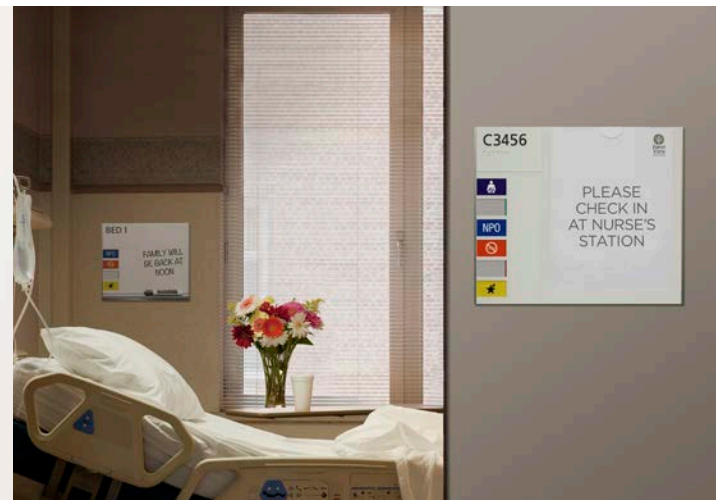

Imagery can be printed on paper inserts to reflect your brand, celebrate holidays, or change with the seasons.

SmartInsert™

Display different messages, revealing or concealing them when needed. Any sign with an insert ranging from 1" to 4" high can accommodate a SmartInsert accessory.



Like all of our modular sign systems, Slide modular signs are easily updated to meet the needs of changing environments and office layouts.

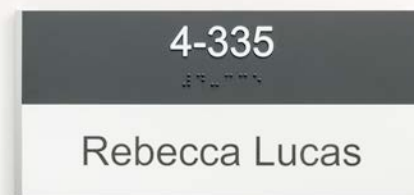
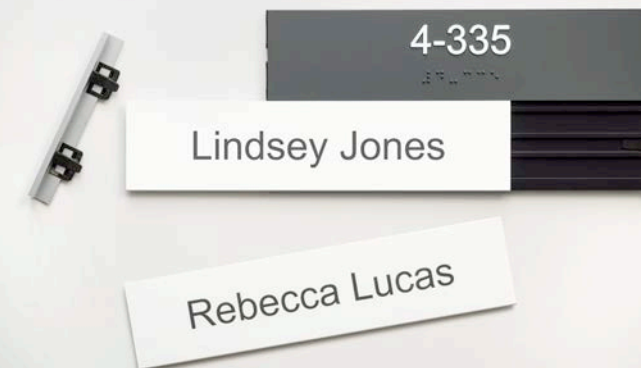

Slide™

modular sign system

The extensive variety of three basic components (Rails, Inserts and End Caps) allows the Slide modular sign system to be customized into a near infinite variety of sizes, finishes and configurations. **When changes occur, simply replace the copy insert rather than the entire sign with your own printed inserts, or use replacement inserts from 2/90 Sign Systems.**

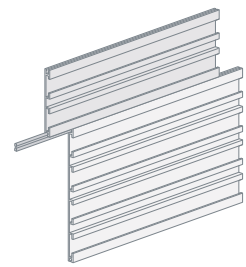

Rails

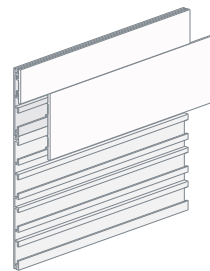

Inserts

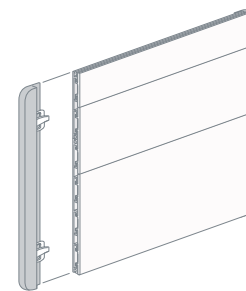

End Caps

You can create a family of signs using colored inserts to designate specific areas or sign functions.

Our team of experts take the worry out of ADA compliance by making sure your signs meet all government regulations.

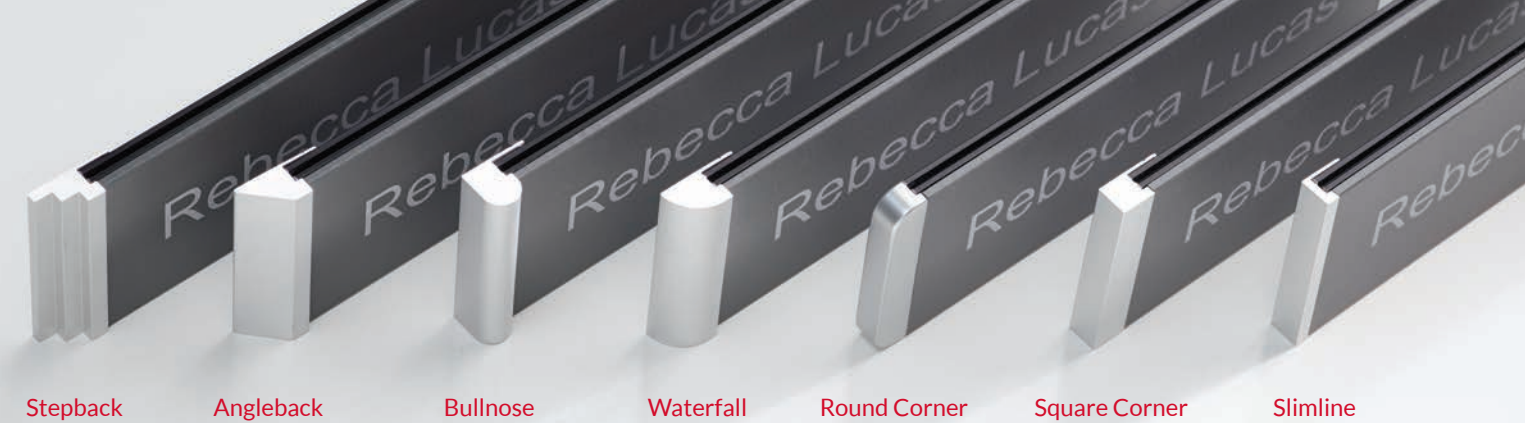
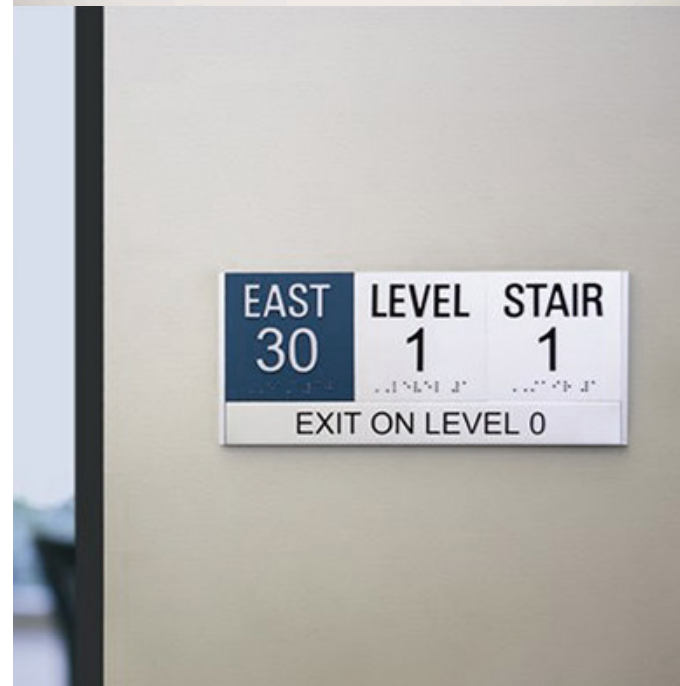

Slide End Caps

Seven styles are offered in natural anodized aluminum, and any standard or color match paint.

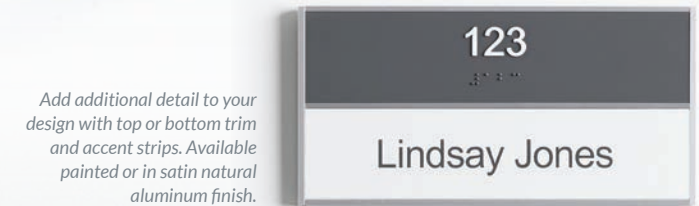

Add additional detail to your design with top or bottom trim and accent strips. Available painted or in satin natural aluminum finish.



Structural Rails

Thin, Standard and Box rails allow you to customize your Slide modular sign system for one or two-sided applications as well as situations where heavy duty construction is required.





When the path reveals itself, follow it.

4-335

٤٣٣٥

Lindsay Jones

The give and take of corporate life. Maybe it's an intense budget meeting, or a happy retirement party. No matter what's on the agenda, clear and professional signage from 2/90 Sign Systems ensures that employees and visitors alike find their way. Wherever wayfinding products are needed, there is a 2/90 Sign Systems solution that is **helping people find their way.**

2/90[®]
Sign Systems

Helping people find their way™

Klik™

modular sign system

The Klik modular sign system consists of flat panels with changeable inserts that subtly let visitors and employees alike know that you're a professional organization that sweats the details. The frameless Klik baseplate holds front-loading, removable copy inserts, creating an attractive and efficient choice for corporate environments large and small. Choose Klik when you're looking for fine detail in a clean, sophisticated presentation.



ADA-compliant graphics identify permanent locations.



The SmartInsert™ status selector reveals and conceals room availability.

Our modular sign systems include a collection of wall, cubicle, ceiling and table top mounts, including this Klik free-standing mount.



Regulatory and life-safety signs assist staff and visitors to egress safely during an emergency.



Directories help visitors find locations effortlessly, while directional and overhead signs show them the way.

Klik™

modular sign system

The Klik modular insert is surrounded by a beveled edge detail that forms a reveal between the individual inserts.

Klik is designed for easy updates, letting you change inserts whenever needed instead of changing the entire sign.

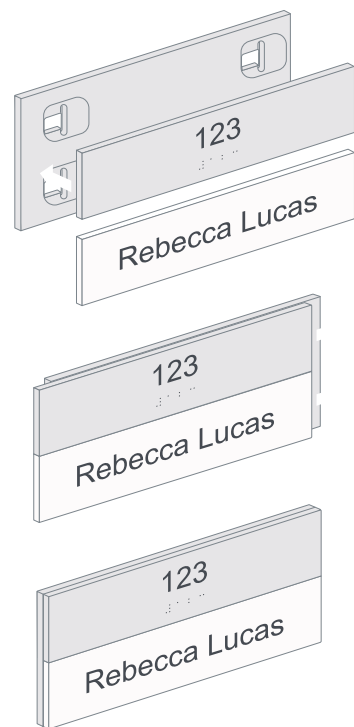

Each 3/16" insert slides and clicks into place in the 1/4" thick painted acrylic baseplate. Inserts with locking mechanisms are also available for securing your message.



The Klik key allows for easy insert removal when the tamper-resistant option is chosen. Simply insert the key into the side opening to release the patented locking tab.

When change is not required, choose KlikLESS. The signs have the look and feel of their Klik counterparts while lowering the overall project costs.



Klik arch shaped Enhanced baseplate.

Enhanced™

Enhanced allows you to incorporate additional imagery, a company logo or other visual elements to your Klik sign system. Choose from a selection of shapes, colors and materials that are in alignment with your company, building or brand.



Klik quad shaped Enhanced baseplate.



Klik wave shaped Enhanced baseplate with additional backer.

In addition to the standard baseplate, five different shapes are available in a variety of patterns and colors.

2/90 Sign Systems Essentials™

Whether you're in healthcare, education, business, hospitality or more, Essentials is an "Anxiety Remover" only 2/90 Sign Systems can offer. With Essentials you simply choose your style: Arc, Slide or Klik, and then your 2/90 Sign Systems expert will create an Essentials program-package that covers all the bases – the signs you want, and most importantly, the signs you need. We can even help install and maintain them for you. **When you choose Essentials by 2/90 Sign Systems, we remove any and all concerns about getting it right – the first time.**



Essentials works to help you plan, purchase and conform to code.

When finishing out, refurbishing or redesigning a workplace or facility, it's easy to overlook the essential sign details. Beyond the art and design, so much of signage is mandated and automatic – restrooms, parking, elevator, fire exits... and so on. Your 2/90 Sign Systems Essentials package will include everything necessary to complete your wayfinding buildout, including a selection of signs to identify, inform, regulate and direct your visitors and staff.

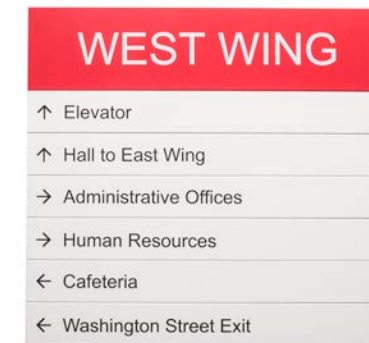

We've chosen our most popular sizes, insert configurations, and options. All you have to do is choose your sign system and colors. It's that easy!

Standard mounts for Essentials include adhesive and screw. Optional mounts are also available for specific applications.





Bespoke

your designs brought to life

2/90 Sign Systems was founded by industrial designer Charlie Tyke, so when it comes to our appreciation of design and designers, our company DNA goes deep. Our entire company, including manufacturing, is located in Grand Rapids, MI. This vertical integration not only allows for quick turnaround of "catalog" orders, it also allows us to work directly with designers looking for everything from custom fabrication to unique installations and more. **The 2/90 Sign Systems Bespoke program allows you to bring any vision to life.**



Our years of experience and commitment to customer service make 2/90 Sign Systems the fabricator-of-choice.



2/90 Sign Systems can provide interior, exterior, static and digital turnkey solutions with dimensional letters, wall graphics and more.





Helping people find their way isn't something we do, it's what we do.



Helping people find their way is more than just helping a customer find the parking lot, or a patient find the radiology lab. 2/90 Sign Systems is all about helping everyone find their way through the maze of regulations, design decisions and more. At 2/90 Sign Systems, we make it easy to select, install and maintain your wayfinding system.



Helping people find their way™



Sign Systems

Helping people find their way™

2/90 Sign Systems is the evolution of the original wayfinding system first created by Charlie Tyke in 1979. We are the pioneers in the wayfinding industry, with an extensive line of long-lasting, modular products that are designed and manufactured in the U.S.A. to the highest quality. We offer turnkey, regulation-compliant wayfinding solutions from concept and design, to installation, maintenance and repair.

